

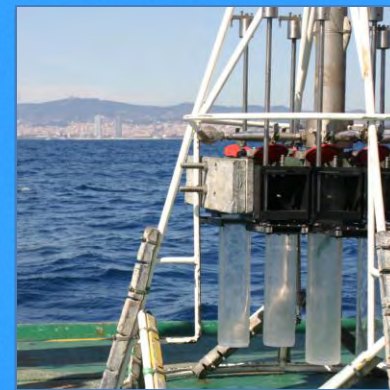

# Environmental Radioactivity Laboratory

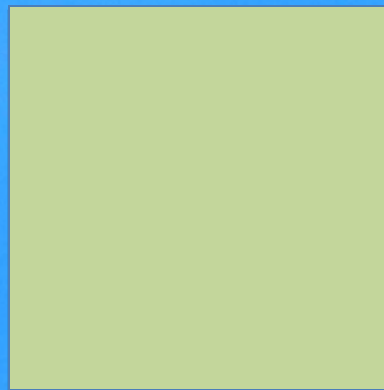
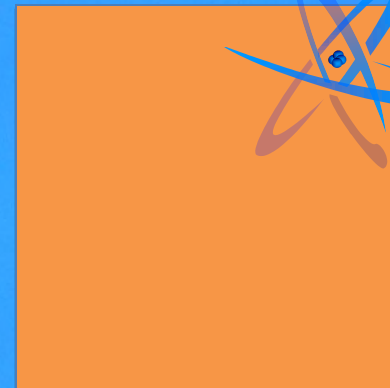
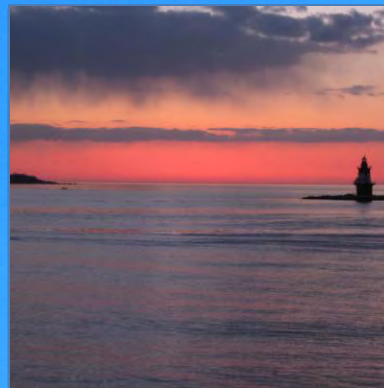

ICTA – October 2010

# Research

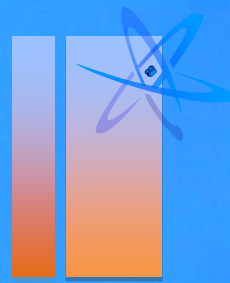

## Laboratori de Radioactivitat Ambiental

@ the Grup de Física de les Radiacions (Departament de Física) & the Institut de Ciència i Tecnologia Ambientals

- Drs. P. Masqué, J. Garcia-Orellana & J.A. Sanchez Cabeza
- Mr. J.M Bruach
- 7 PhD students

Telf: +34 93 581 19 15;

[Pere.Masque@uab.cat](mailto:Pere.Masque@uab.cat)

<http://web.me.com/pere.masque>

# The basics...

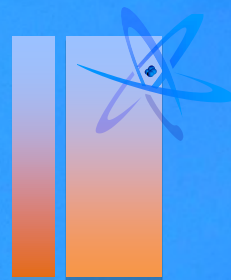

Element	Uranium-238 series					Th-232 series			U-235 series			
Uranium	U-238 4.5*10 <sup>9</sup> y		U-234 245500 y							U-235 7.0*10 <sup>8</sup> y		
Protactinium		Pa-234 1.2 min									Pa-231 32800 y	
Thorium	Th-234 24.1 d		Th-230 75400 y			Th-232 1.4*10 <sup>10</sup> y		Th-228 1.91 y	Th-231 25.5 h		Th-227 18.7 d	
Actinium							Ac-228 6.1 h			Ac-227 21.8 y		
Radium			Ra-226 1600 y			Ra-228 5.75 y		Ra-224 3.7 d				Ra-223 11.4 d
Francium												
Radon			Rn-222 3.8 d									
Astatine												
Polonium			Po-218 3.1 min	Po-214 0.00014 s		Po-210 138 d						
Bismuth				Bi-214 19.9 min		Bi-210 5.0 d						
Lead			Pb-214 26.8 min	Pb-210 22.3 y		Pb-206 stable		Pb-208 stable				Pb-207 stable

↓ α-decay  
Z: -2  
N: -4

↗ β-decay  
Z: +1  
N: +/-0

⋮ decay series  
of short-lived  
nuclides

symbol of the  
element — Pa-231  
32500 y — mass  
number  
— half-life

particle reactivity  
 low  
 intermediate  
 high



# Main research interests

---

## Using radioactive isotopes

- Cycle of carbon in the upper ocean ( $^{234}\text{Th}$ ,  $^{210}\text{Po}$  &  $^{210}\text{Pb}$ )
- Role of sea ice in interception and transport of atmospheric fluxes in the Arctic Ocean ( $^7\text{Be}$ ,  $^{210}\text{Po}$ ,  $^{210}\text{Pb}$ ,  $^{137}\text{Cs}$  &  $^{239,240}\text{Pu}$ )
- Submarine groundwater discharges ( $^{223,224,228,226}\text{Ra}$  &  $^{222}\text{Rn}$ )
- Naturally Occurring Radioactive materials (U & Th decay series)
- Reconstruction of pollution history ( $^{210}\text{Pb}$ ,  $^{137}\text{Cs}$  &  $^{241}\text{Am}$ )
- Sedimentation processes in aquatic systems ( $^{210}\text{Pb}$ ,  $^{137}\text{Cs}$  &  $^{239,240}\text{Pu}$ )
- Paleoceanography ( $^{231}\text{Pa}/^{230}\text{Th}$ )

# Working areas

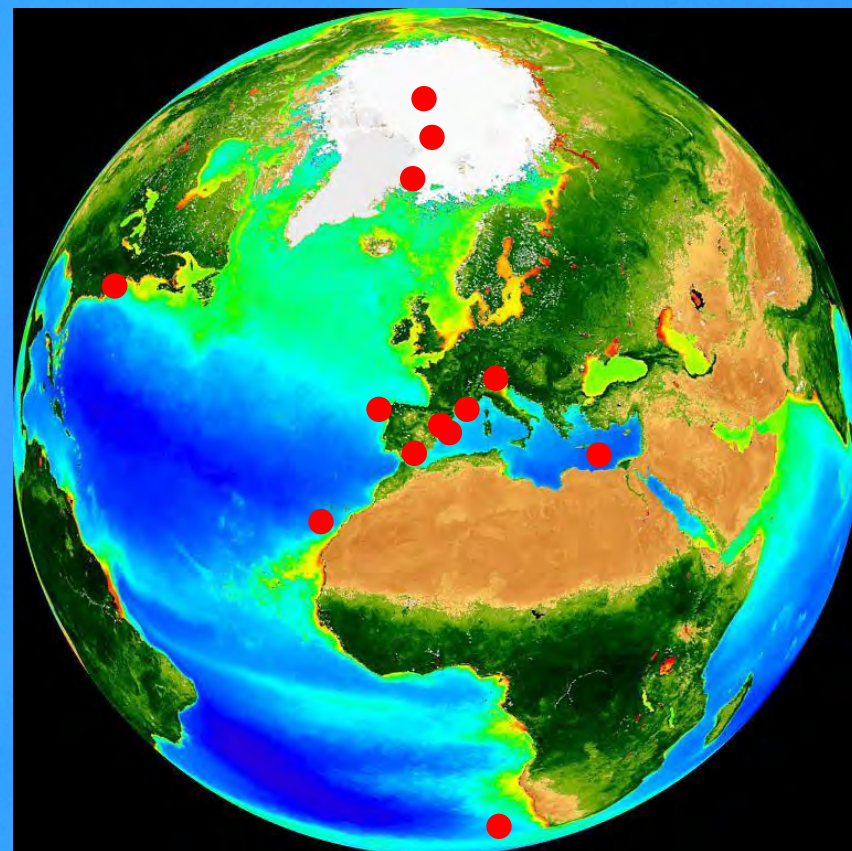
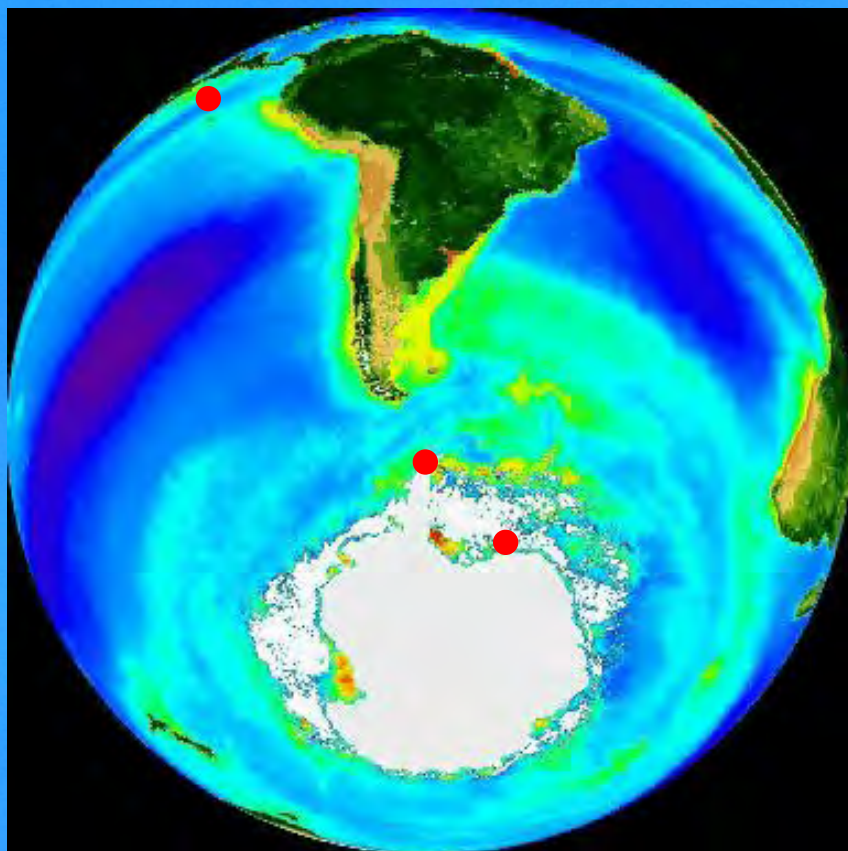
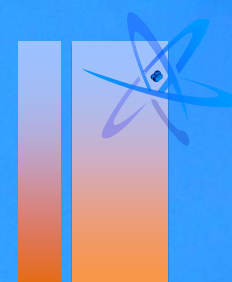

# A few examples

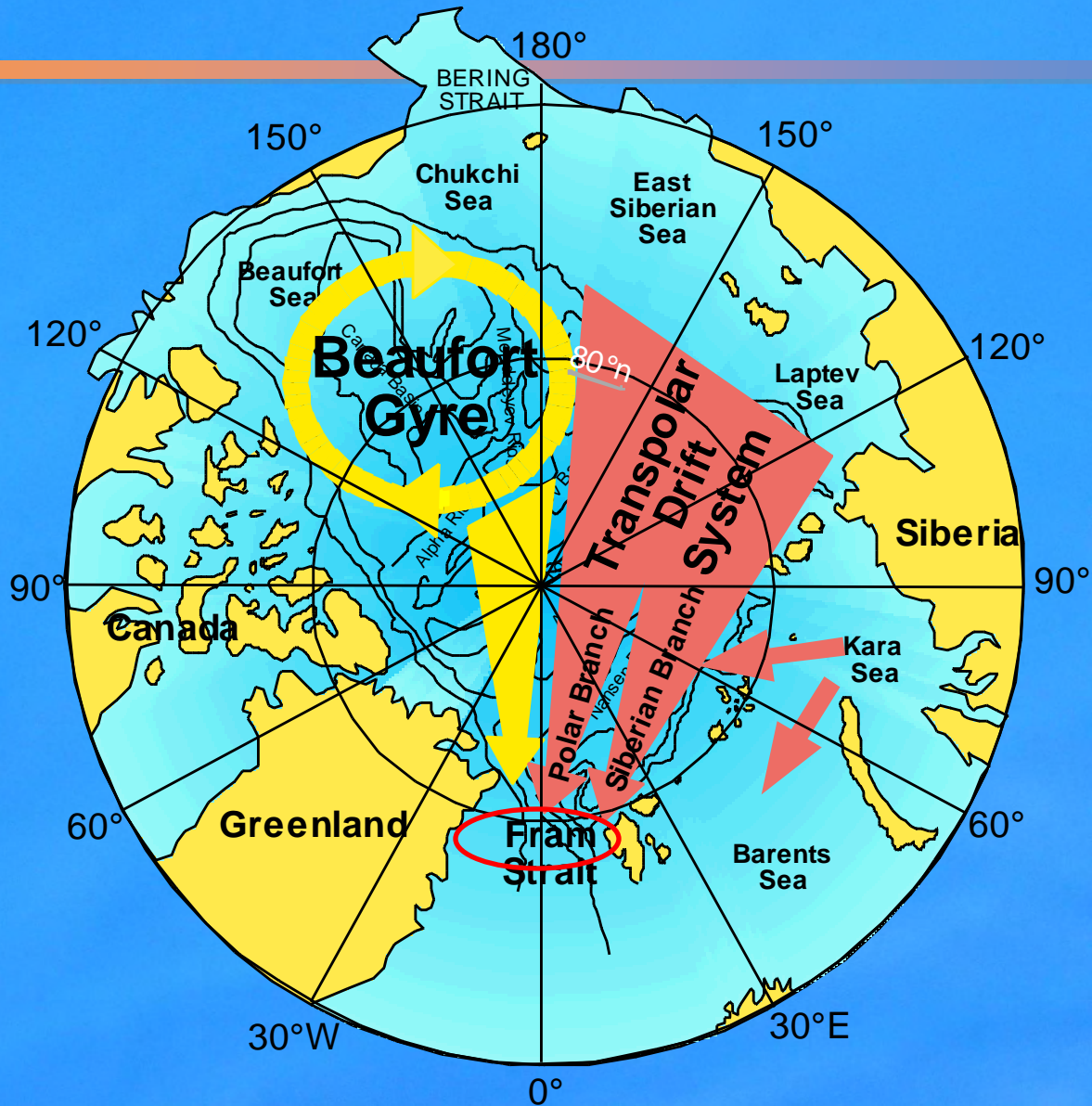
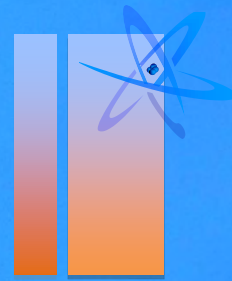

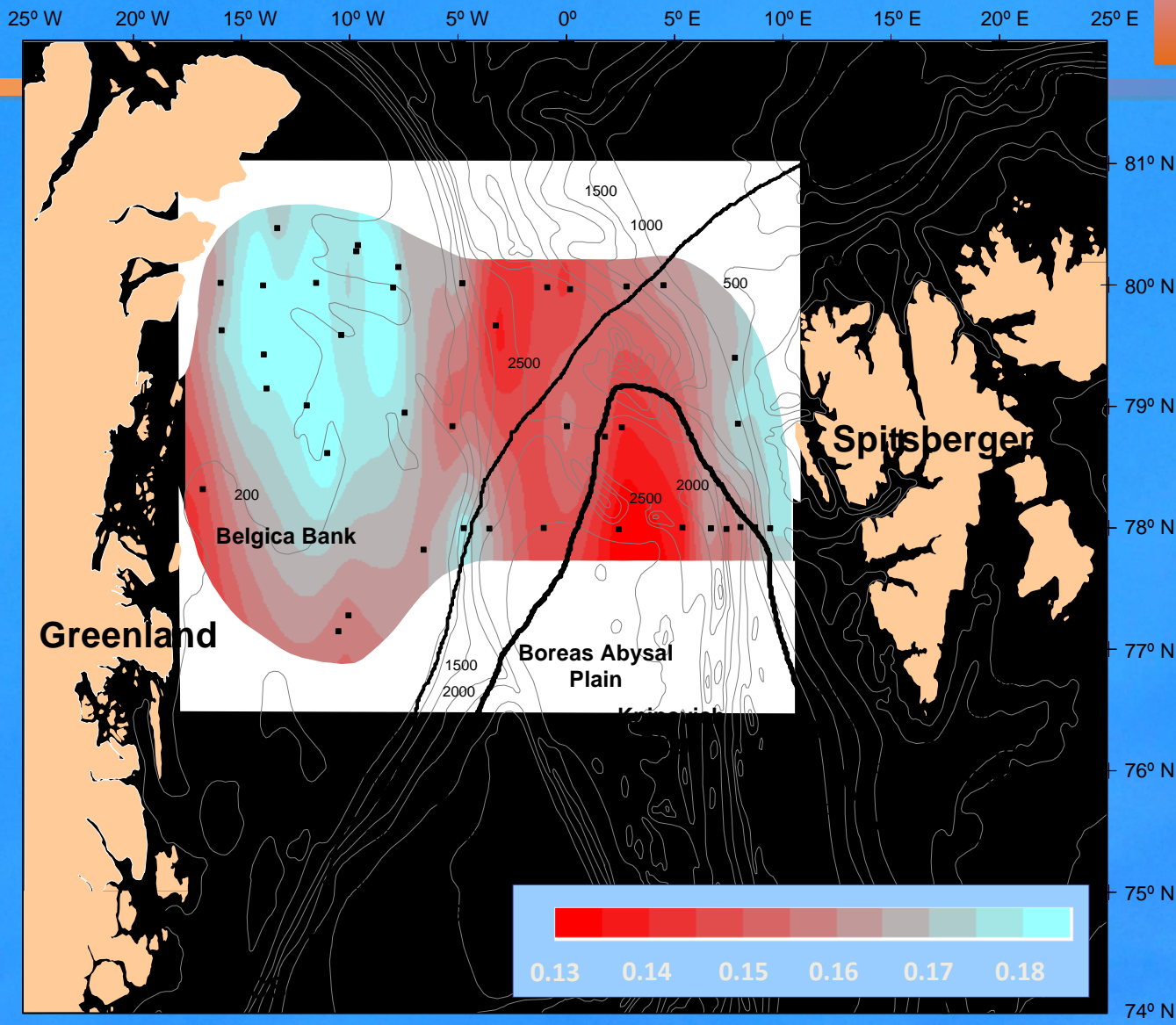



$^{238}\text{U}$  →  $^{234}\text{Th}$

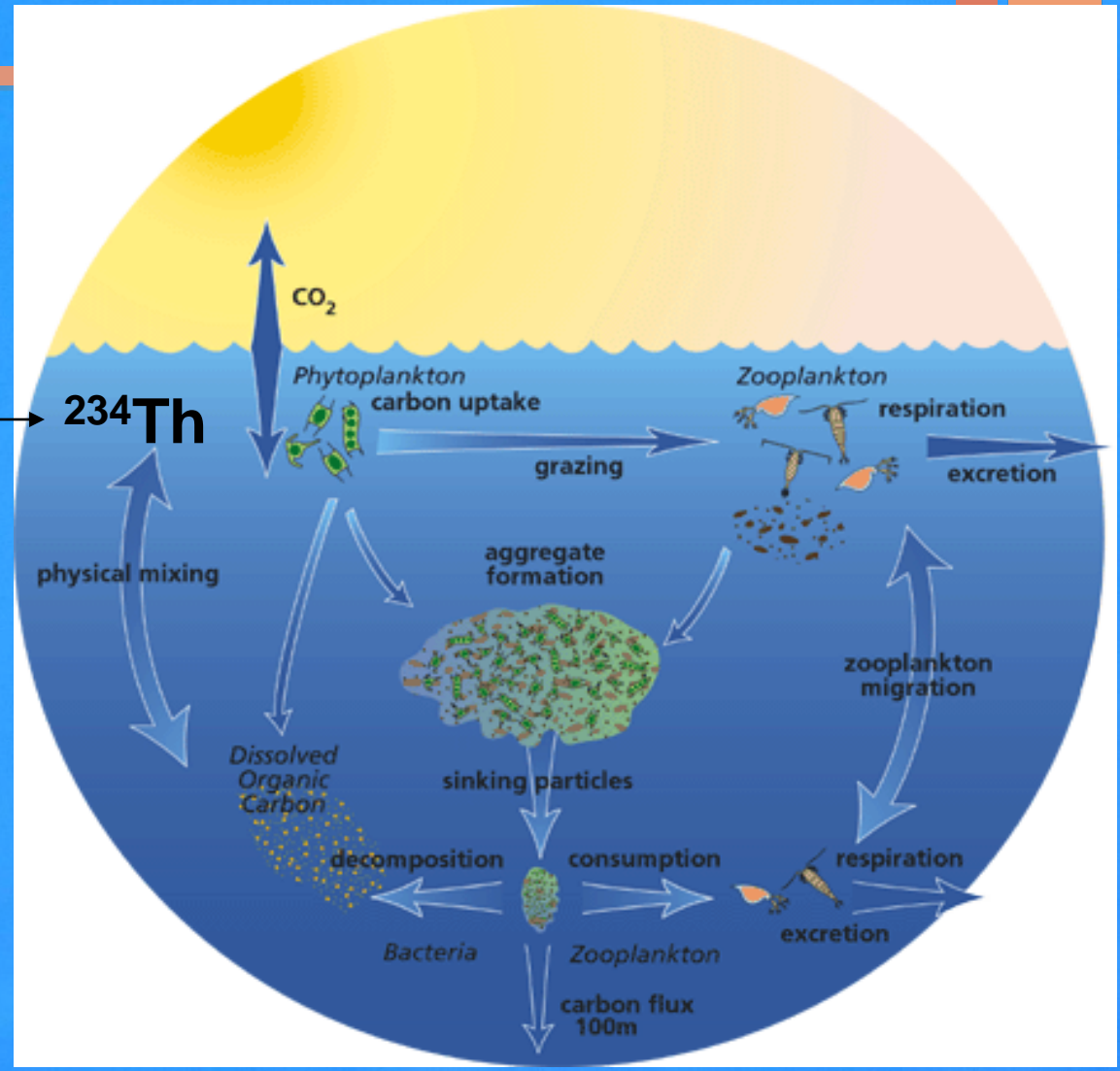
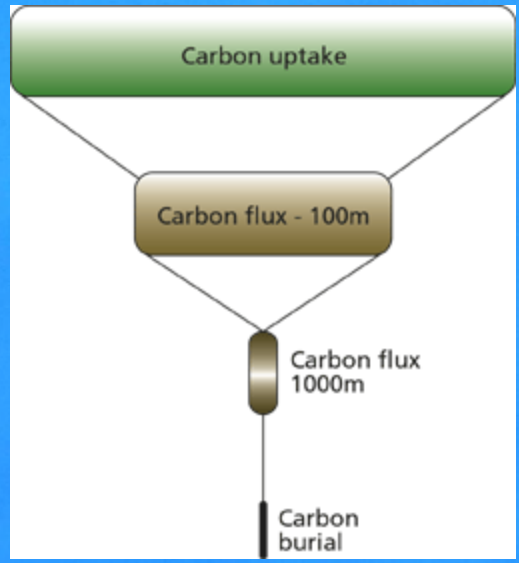

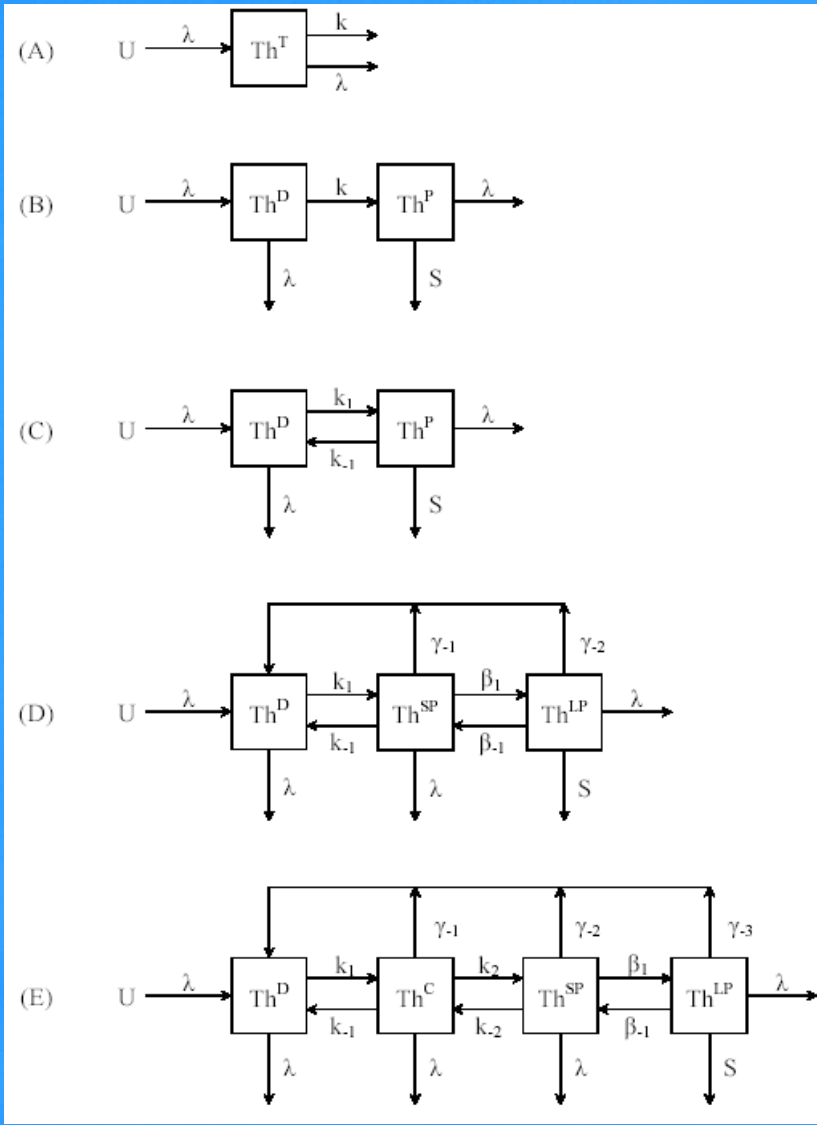

# Disequilibrium $^{238}\text{U}/^{234}\text{Th}$

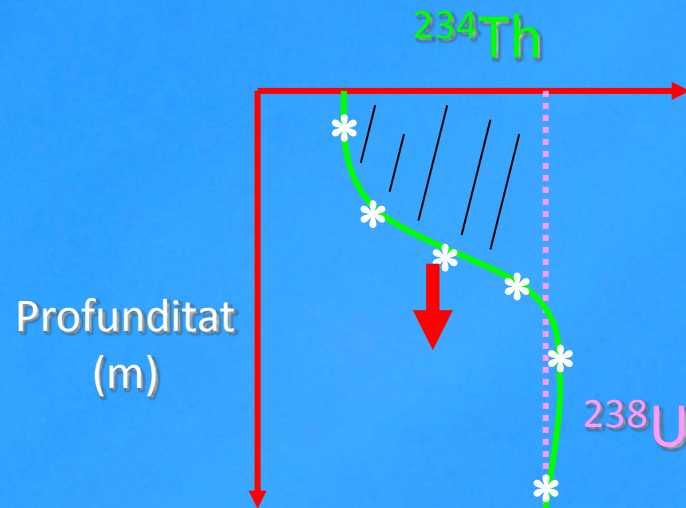

Parent  
 $A_U$

$$P_{\text{Th}} = \lambda A_U$$

Daughter  
 $A_{\text{Th}}$

Export Based on  $^{238}\text{U}/^{234}\text{Th}$ :

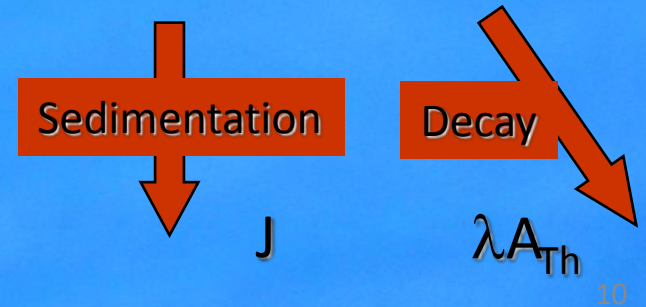

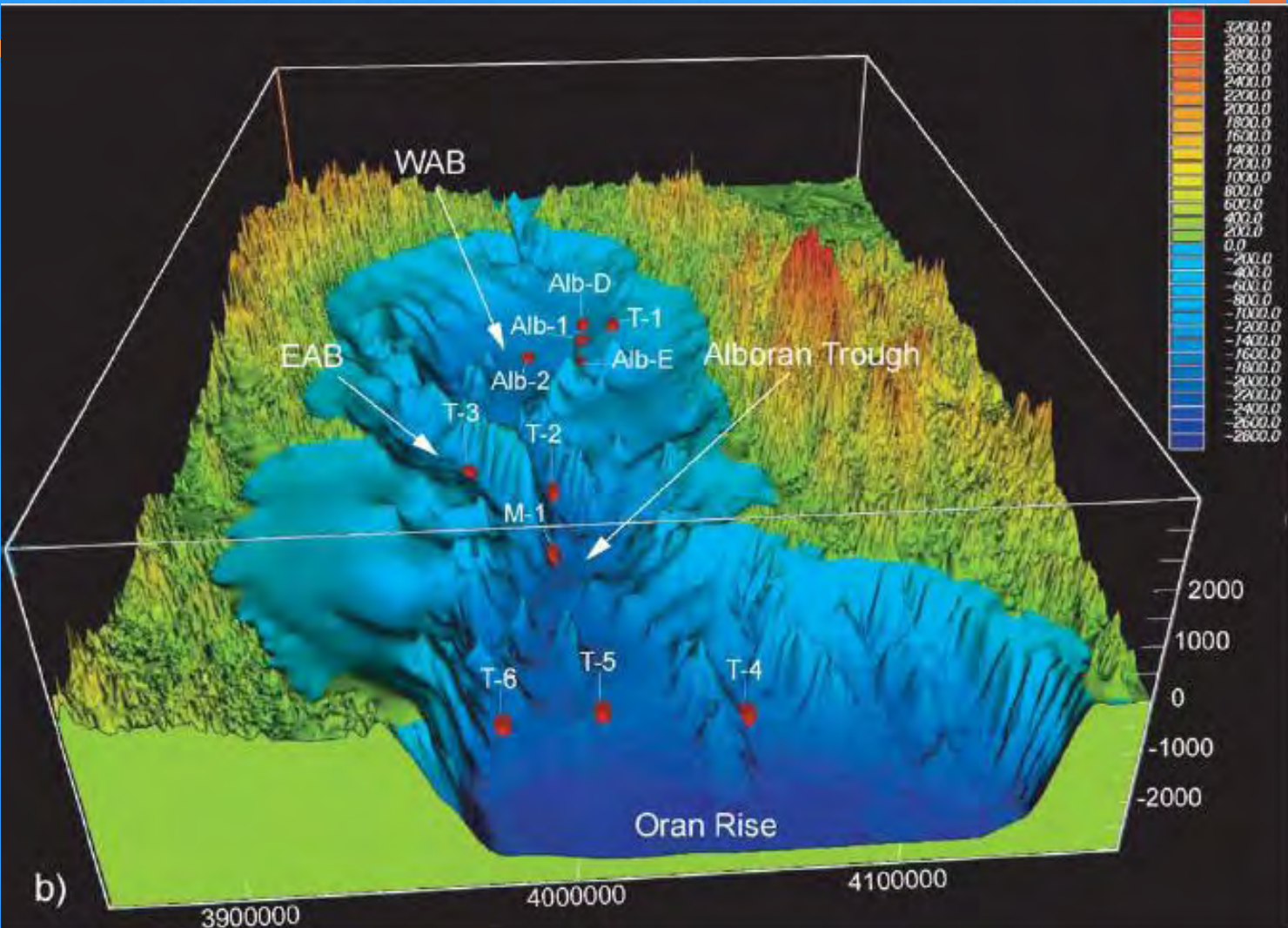

b)

